

■ Baseband - RF connections

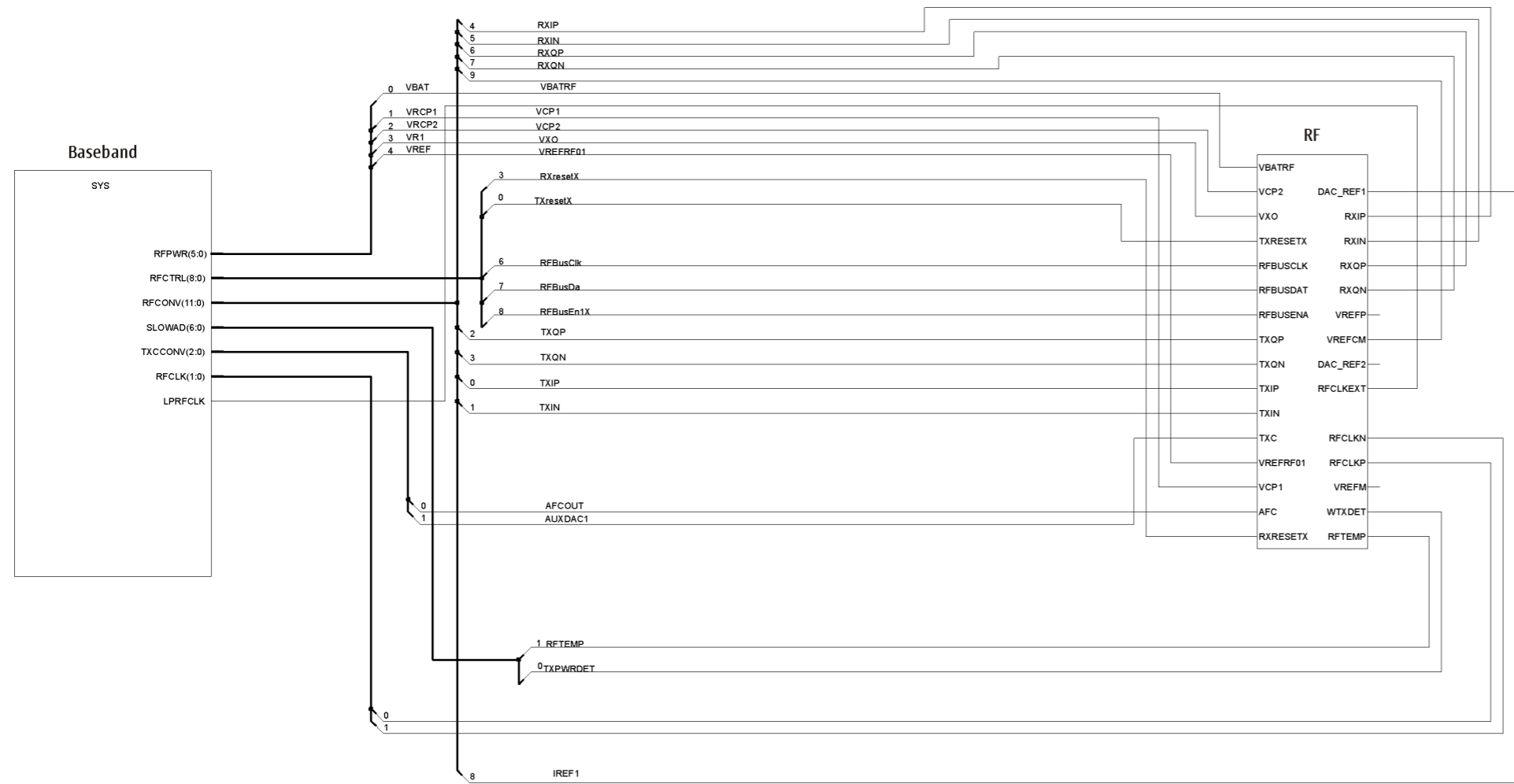

■ System connector

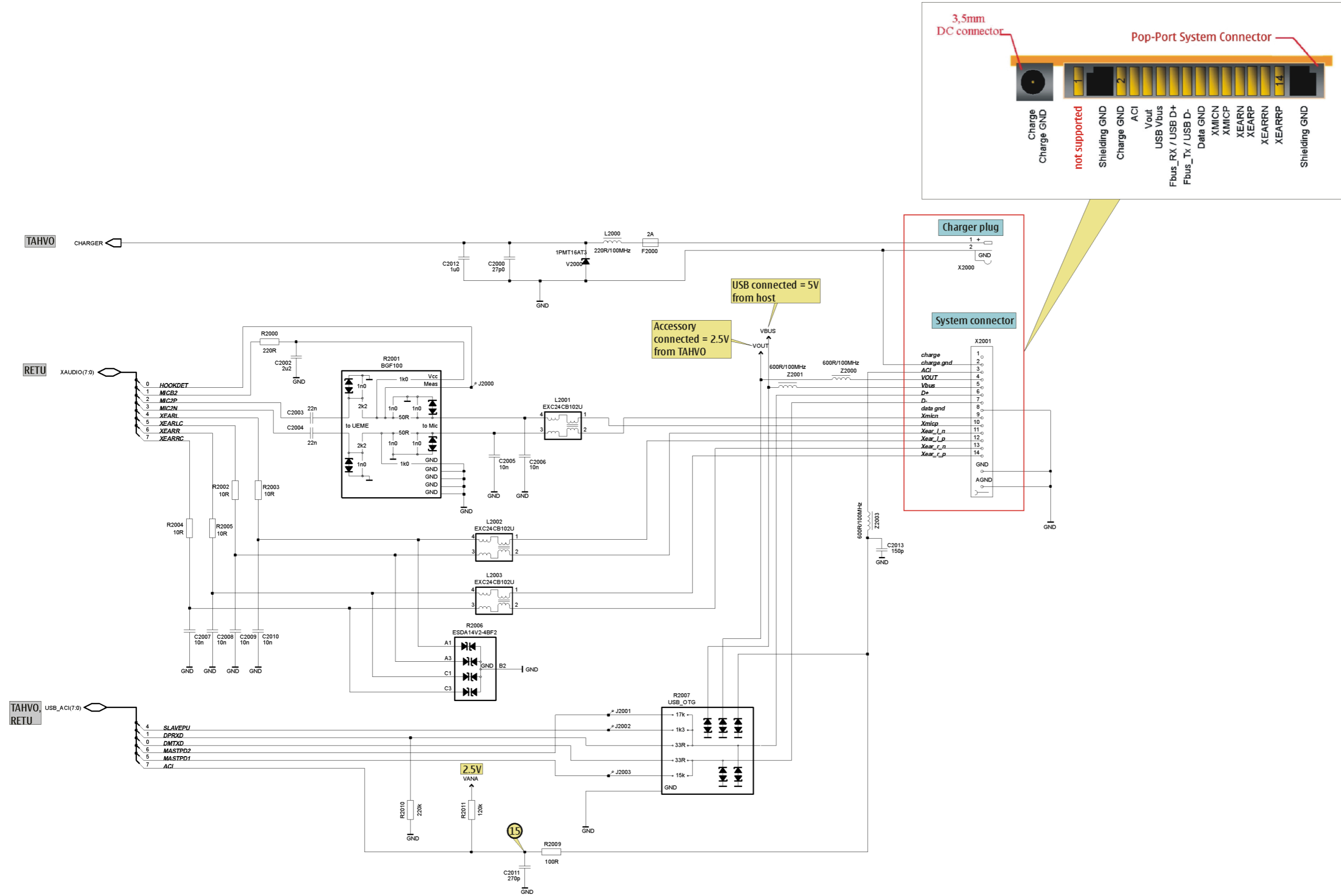

■ RETU, SIM, audio

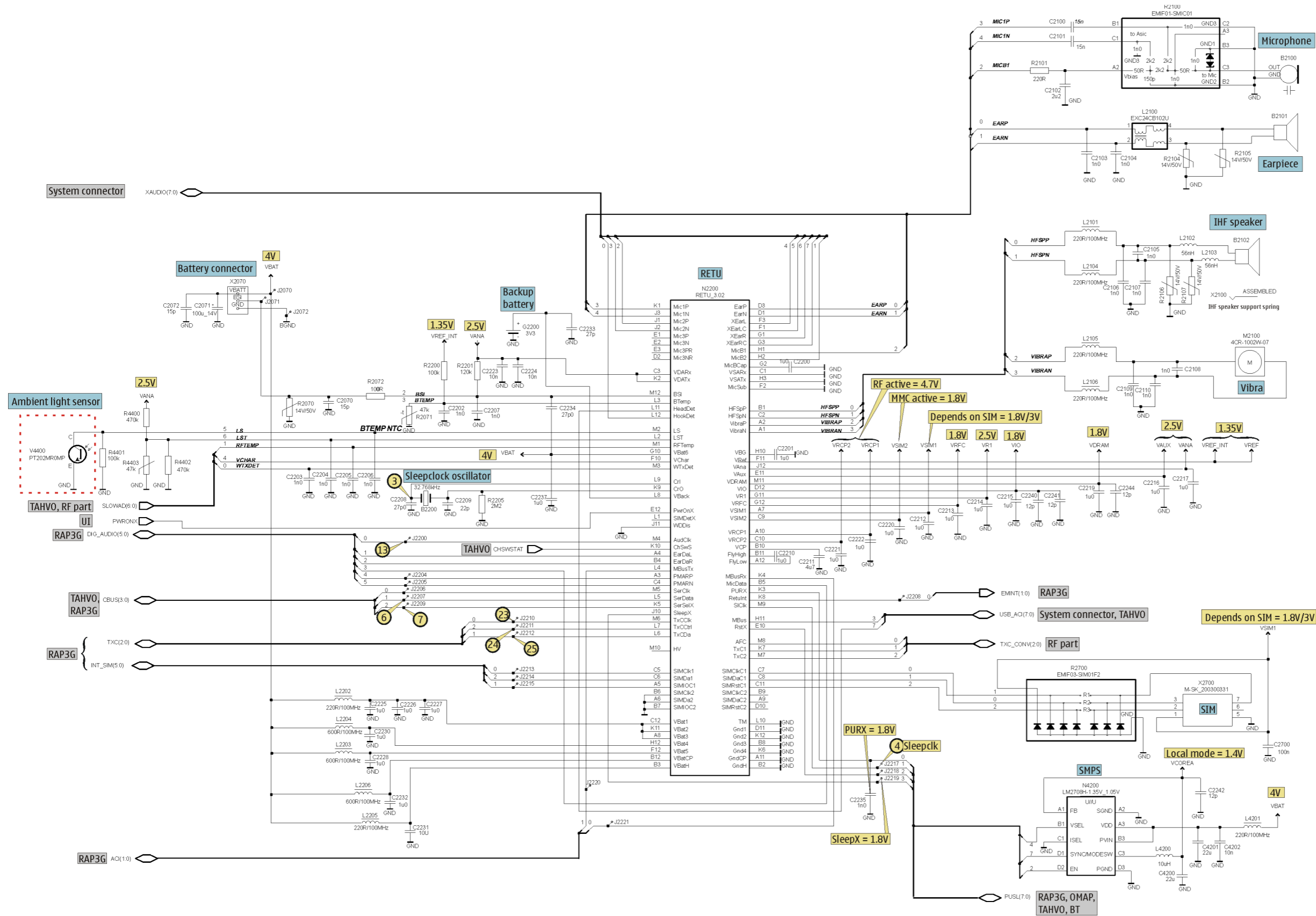

TAHVO

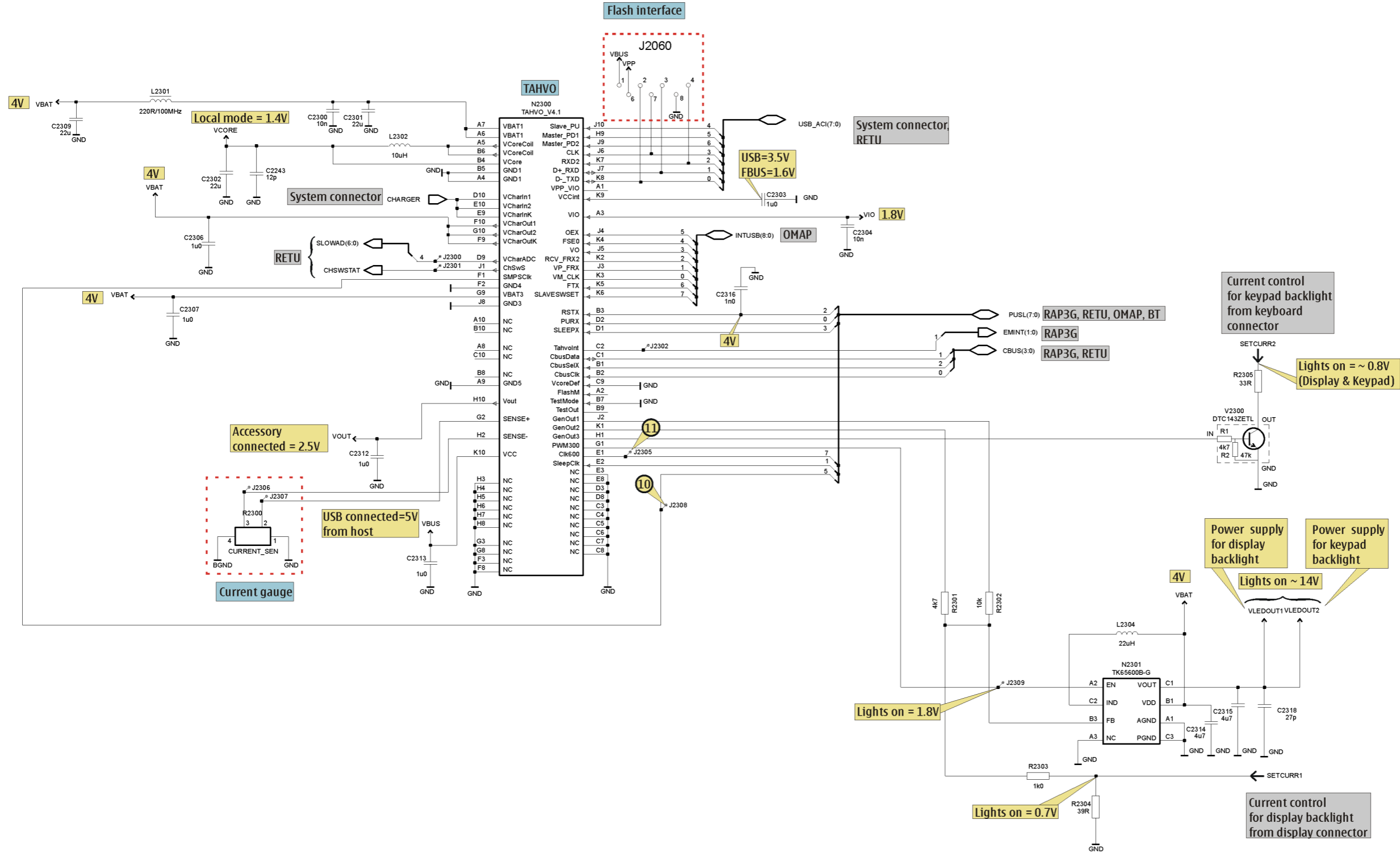

**RAP3G, SDRAM, Flash**

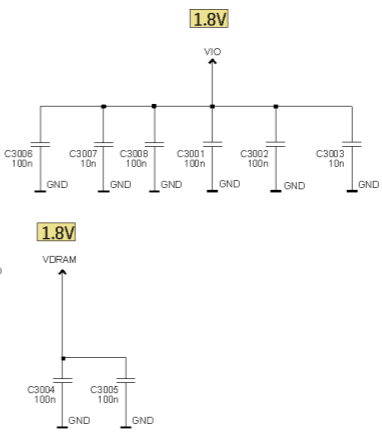
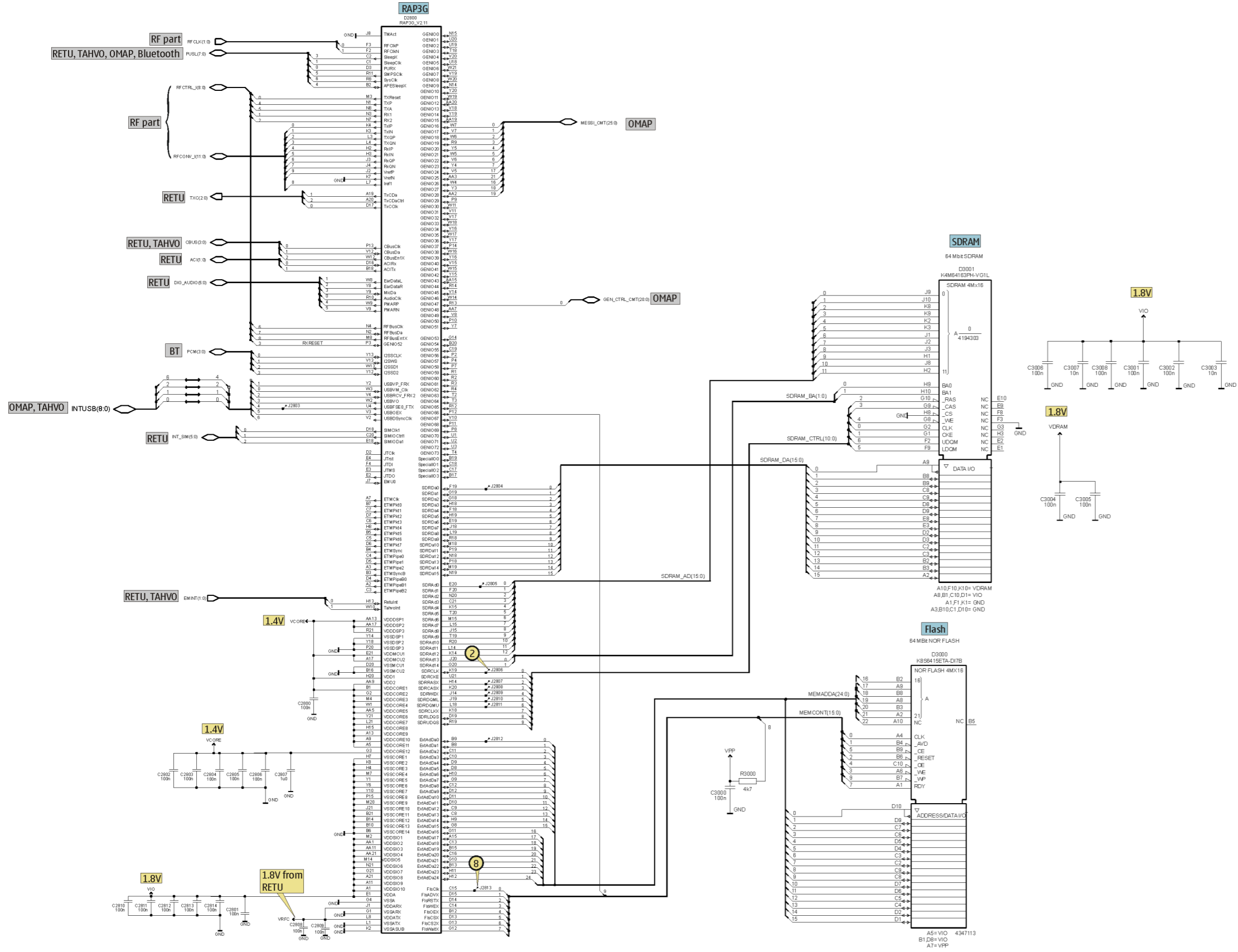

OMAP, combo memory, camera

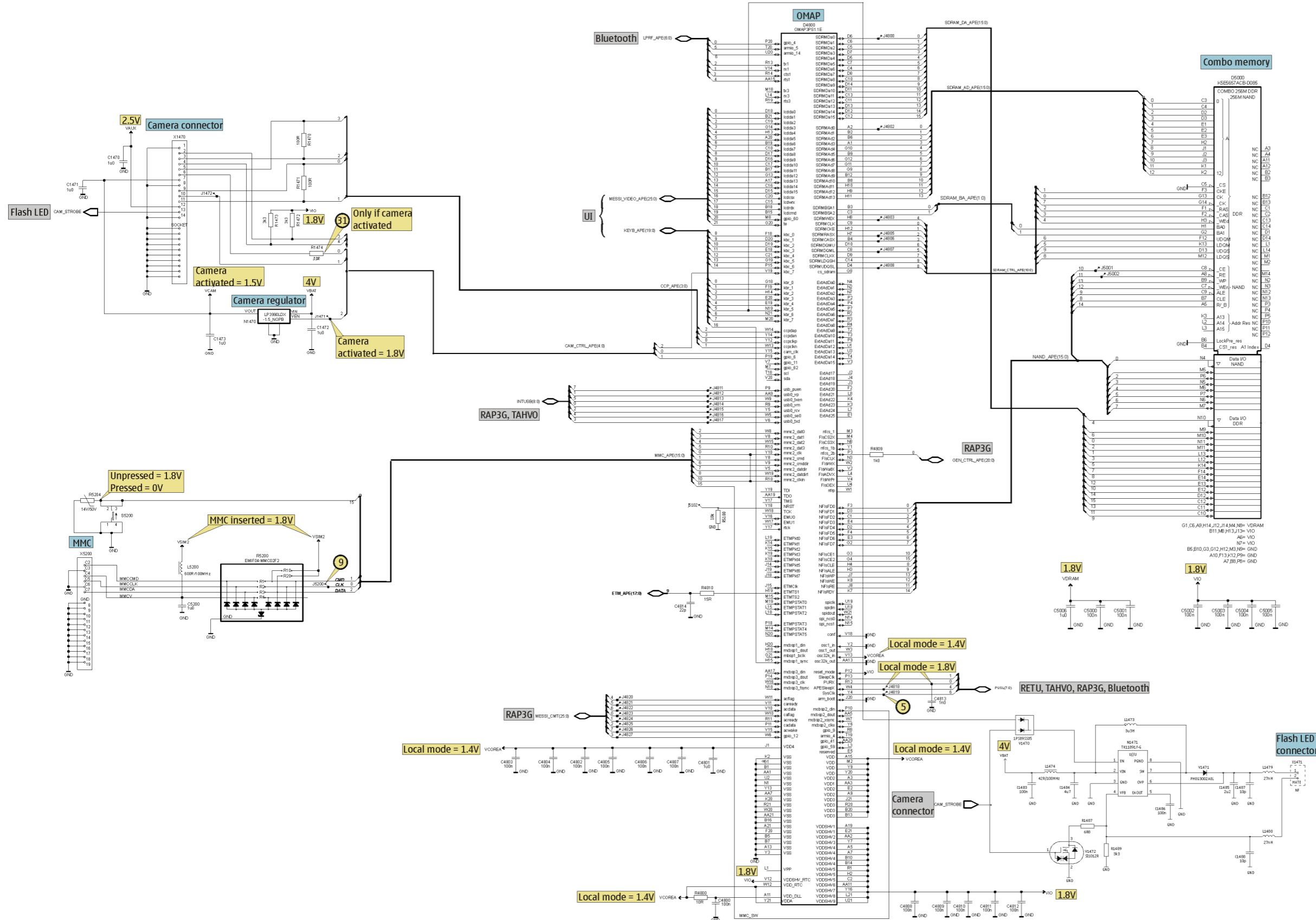



■ B to B connections

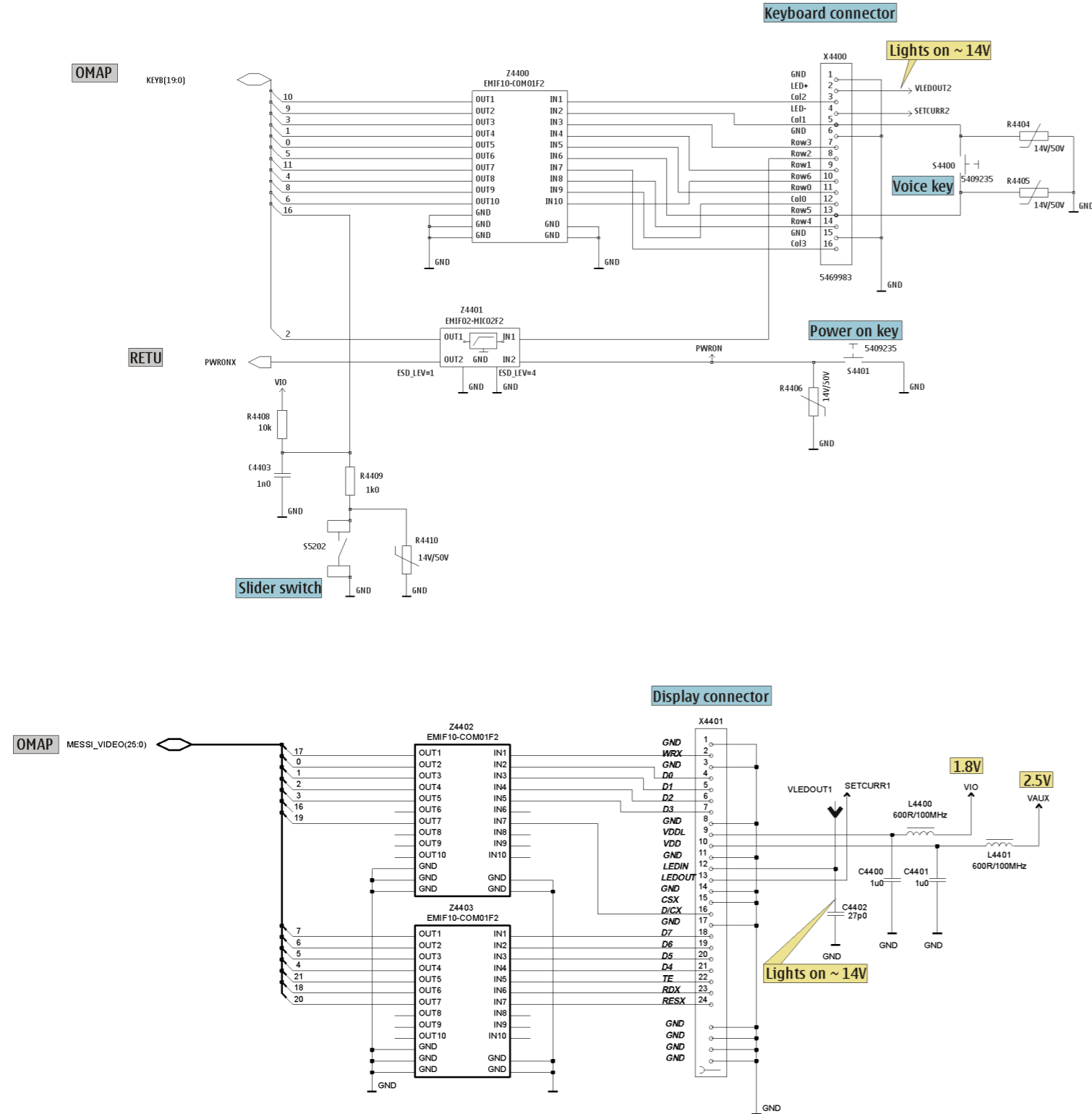



RF part

